



OWNER'S MANUAL

# Stand For LG LED Screen

---

Please read this manual carefully before install & operating your set and retain it for future reference.

## ST-1630F Stand Installation

## Technical Data

Model name	ST-1630F
Material	Aluminum Profile,Steel
Surface Finish	Power Coating (Matte Black)
Recommended Screen Size	163''
Allowable Loads	300kg (Maximum)
Lift Range	0/200/400mm
Certification	CB,CE-LVD,ETL,RoHS2.0
Stand Dimension (W x D x H)	3097 x 1420 x 2200mm 3097 x 1420 x 2400mm 3097 x 1420 x 2600mm
Stand Base Dimension (W x D x H)	2007 x 1420 x 63mm
Caster Wheel Size (Diameter)	63mm
Wooden Case Dimension (W x D x H)	2088 x 1536 x 620 mm
Weight (Net/Gross)	150kg/230kg

**This model (ST-1630F) is a stand for the LAEC018-GN2 AIO model only.**

**The stand has 3 levels to change the height of the screen and comes assembled as LEVEL 1.**

**The height can be changed if needed, and it is described on the page of 4.**



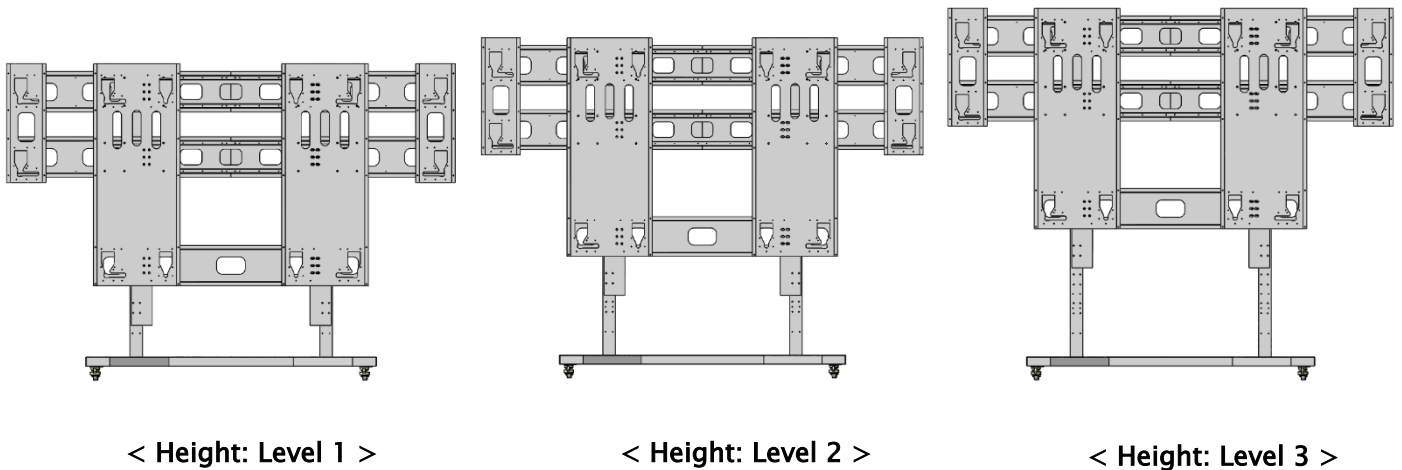

**The distance from the floor to the bottom of the screen is shown in the table.**



**Determine the height of your SCREEN and proceed first if you need to change the height of the STAND.**

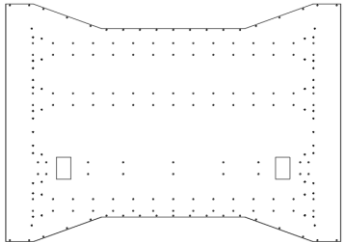
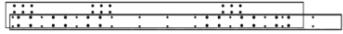
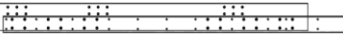
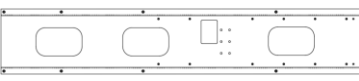
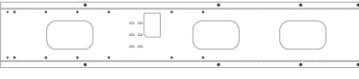
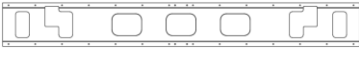

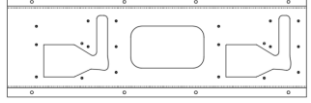
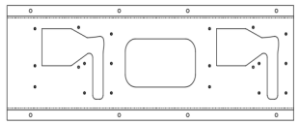
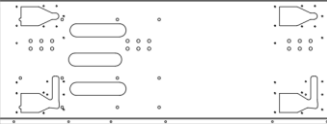
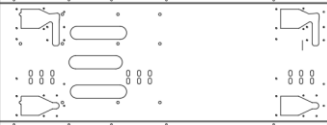
Level	Height
Level 1	≈32cm
Level 2	≈52cm
Level 3	≈72cm

## Packing List

Item	Description	Photo	Qty.
1	Stand Base		1
2	Right Vertical Support Column		1
3	Left Vertical Support Column		1
4	Mounting Frame Horizontal Left		2
5	Mounting Frame Horizontal Right		2
6	Mounting Frame Horizontal Reinforcing Rib		2
7	Mounting Frame Horizontal Support Part		1
8	Mounting Frame Left Part		1
9	Mounting Frame Right Part		1
10	Mounting Frame Middle Left		1
11	Mounting Frame Middle Right		1
12	Screw M8X20mm		30

13	Screw M4X15mm		48
14	Screw M6X20mm		76
15	8mm Hex Key		1
16	Anti-Static Gloves		4
17	Screwdriver		1

**Adjust the stand height (item 2& item 3)**

**Step1. Loosen the screw as the following position.**

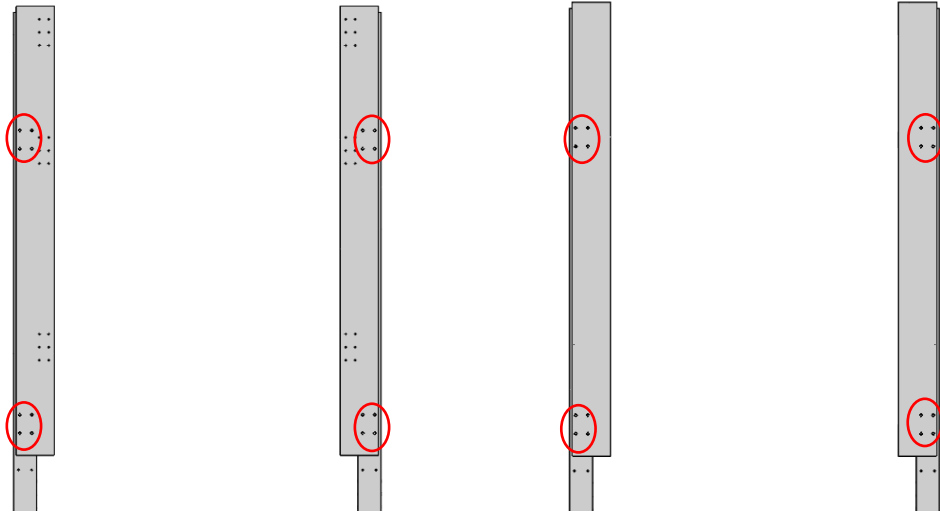

< Front View >

< Rear View >

**Step2. Fixing the screw as following position is Level 2 and Level 3**

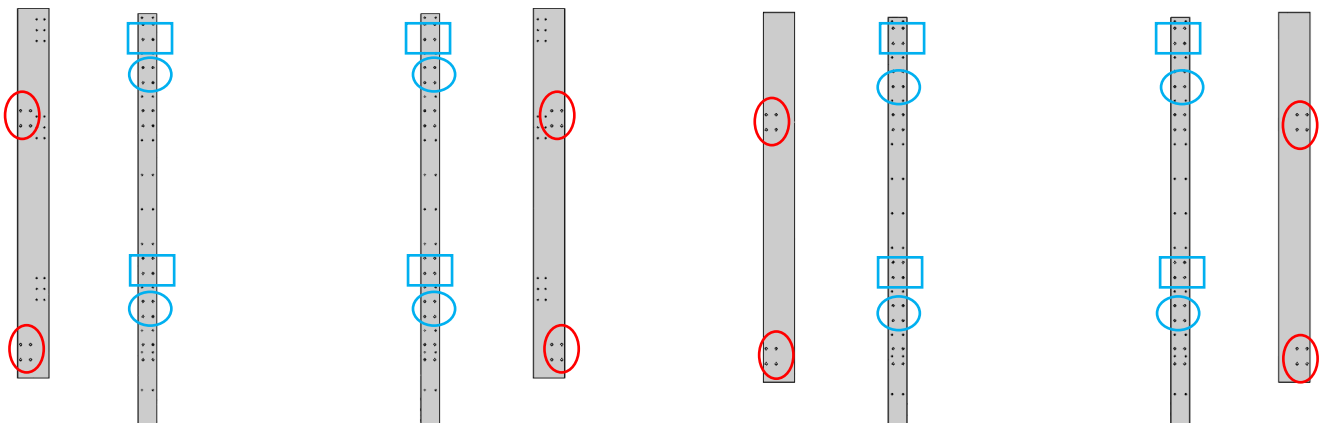

< Front View >

< Rear View >

○ : The position is for Level 2

□ : The position is for Level 3

**Step3. Follow the steps below(from page 6) to connect the plate**

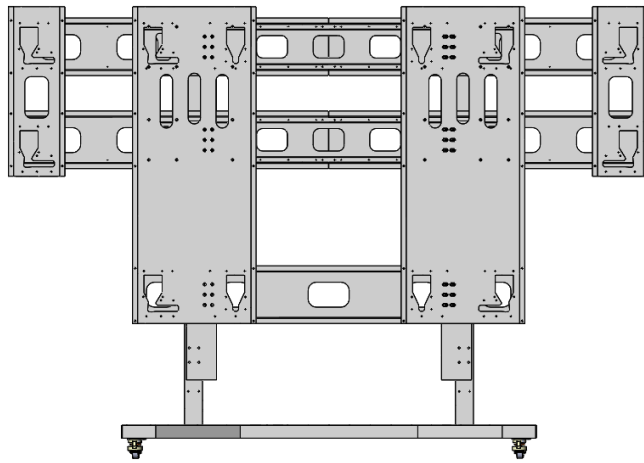

< Level 1 >

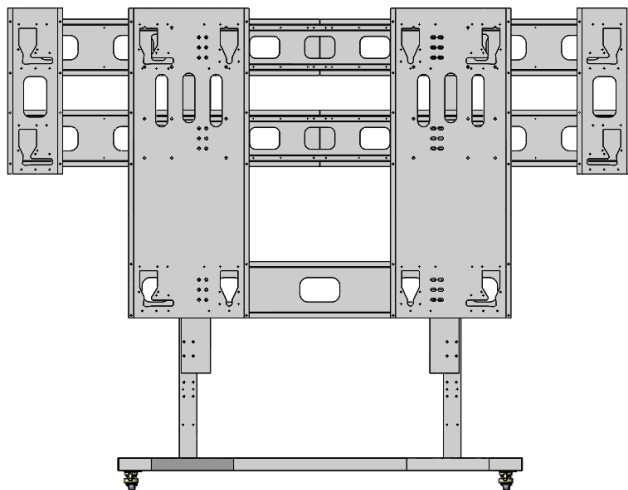

< Level 2 >

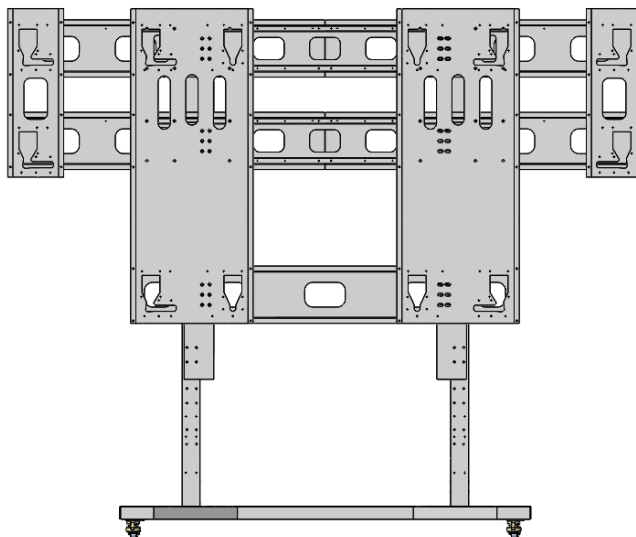

< Level 3 >

## Assemble the stand

**Step1. Install the main body (Vertical Support Column) to the stand base.**

**Note: The front of the vertical support column is where the tapped holes for the screws are visible.**

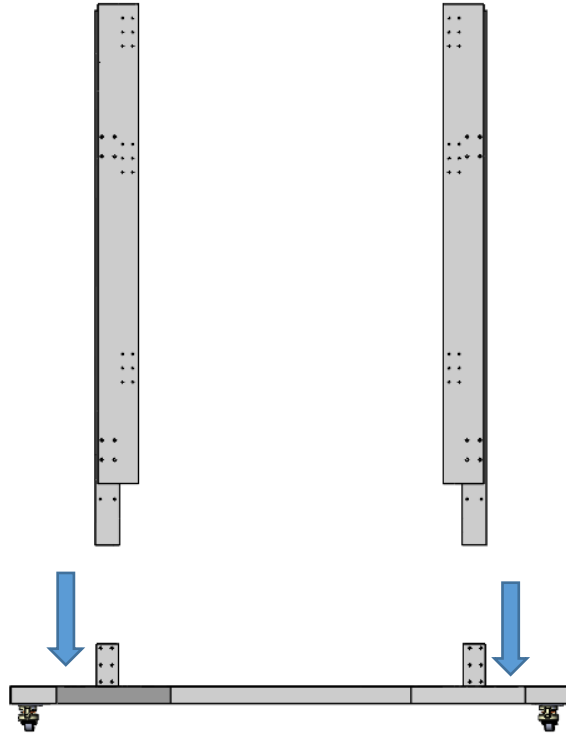

Use 30pcs M8X20 screws (Item 12) to install the Item 2 and Item 3 on the stand base (Item 1).

**Step2. Connect the panel mounting plate.**

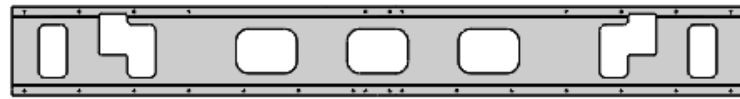

Use 24pcs M4X15 screws (Item 13) to connect Item 6 to the Item 4 and Item 5.

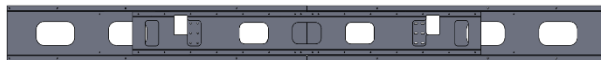

< Front View >



< Side View >

**Step3. Make one more in the same way as step 2.**

**Step4. Install the panel mounting plate to Vertical Support Column.**

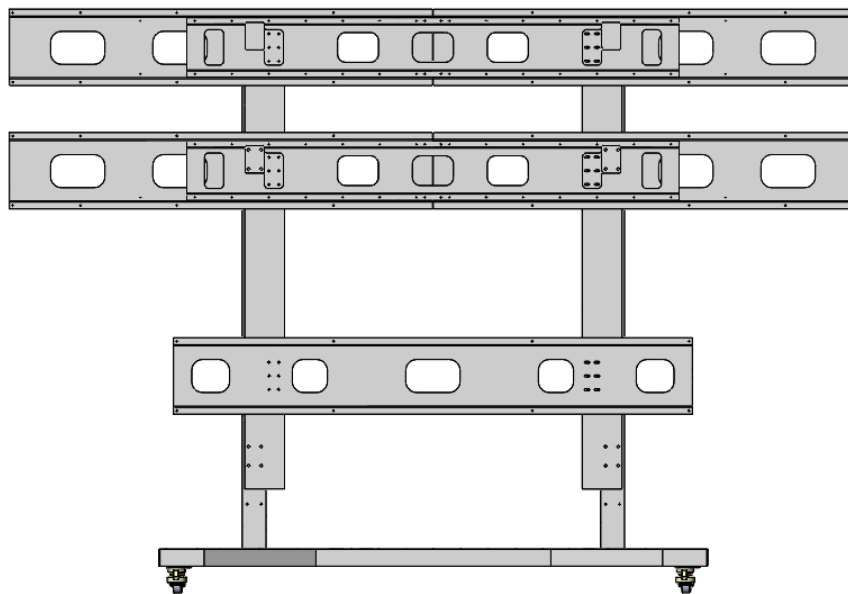

Use 36pcs M6X20 (Item 14) hexagon socket head cap screws to install Item 7 and assembly parts in step 2 onto Item 2 and Item 3.



**Step5. Install the panel mounting plate to the main body mounting bracket.**

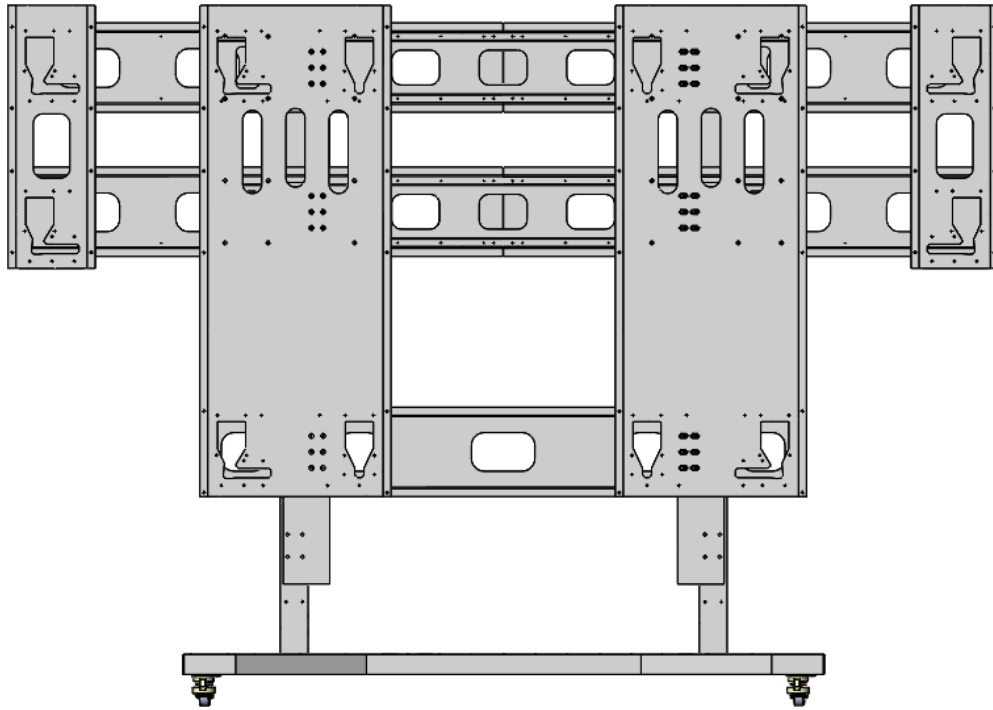

Use 40pcs M6X20 (Item14) hexagon socket head cap screws to install Item10, Item11, Item8 and Item9 to the main body mounting bracket.

## Screen assembly

The 12 PCS fixed screw behind the cabinet are assembled to the cabinet and locked with tools.



Hex screw + Mounting lock

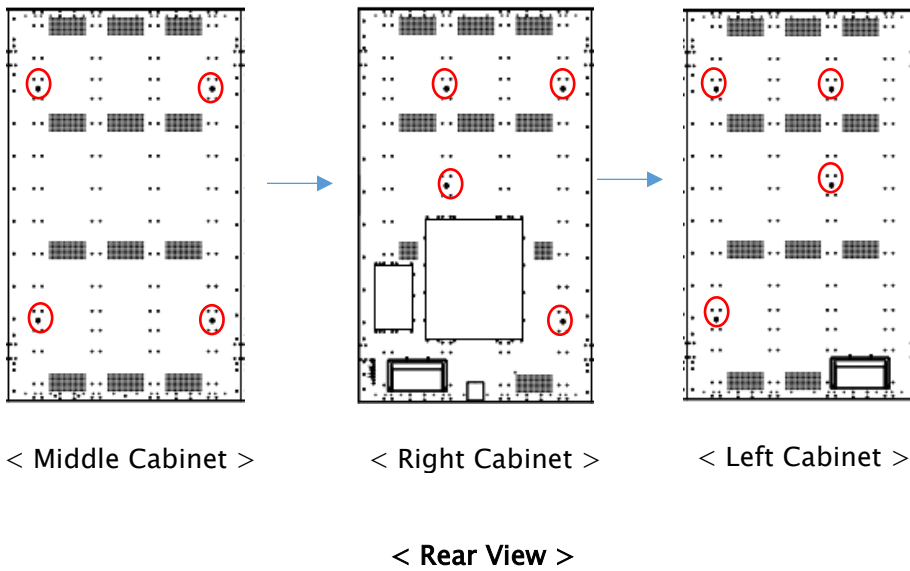

**Note: Please follow the order of the arrows to install the screen.**



The model and serial number of the product are located on the back and on one side of the product. Record them below in case you ever need service.

MODEL

---

SERIAL

---

NO.

Temporary noise is normal when powering ON or OFF this device.